

MANHOLE COVER – LETTERS TO BE MARKED "SANITARY SEWER"

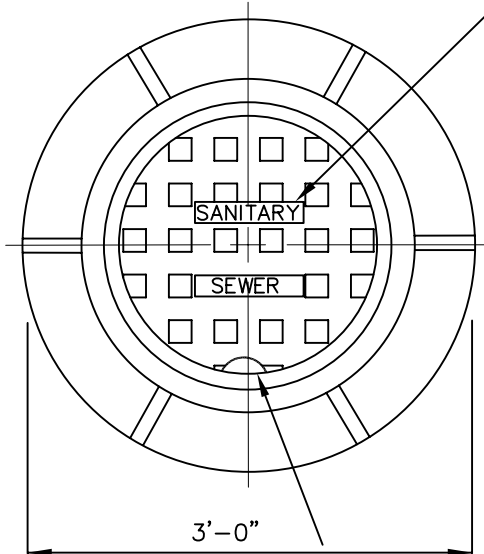

CONCEALED WATERTIGHT PICKHOLE

PLAN VIEW

WATERTIGHT BOOT RAIN GUARD (AS REQUIRED)

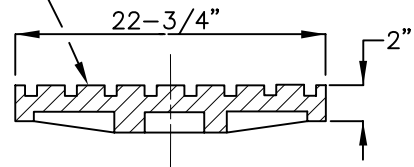

COVER – SECTION

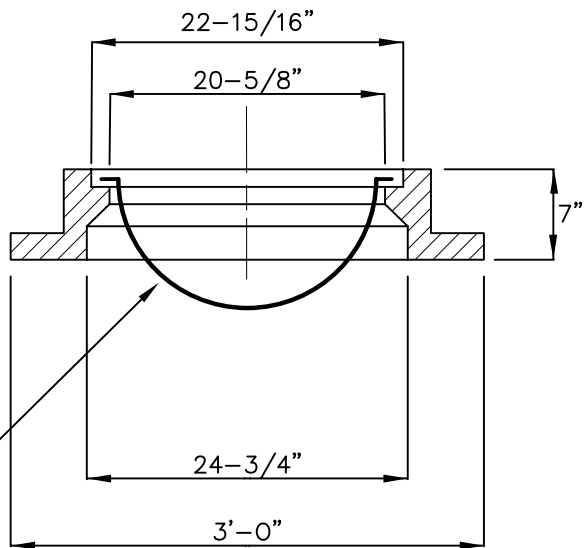

FRAME – SECTION

NOTES

1. A WATERTIGHT BOOT RAIN GUARD SHALL BE PROVIDED FOR ALL MANHOLE FRAME/COVERS AND APPROVED BY INDIAN RIVER COUNTY DEPARTMENT OF UTILITY SERVICES.
2. ALL MATERIALS ARE TO BE PER IRCDUS APPROVED MANUFACTURERS' PRODUCT LIST.

INDIAN RIVER COUNTY  
DEPARTMENT OF  
UTILITIES SERVICES



STANDARD  
MANHOLE CASTING

SEPTEMBER 2011

DRAWING  
NO.

S-3