

ELEVATION
SECTION A-A

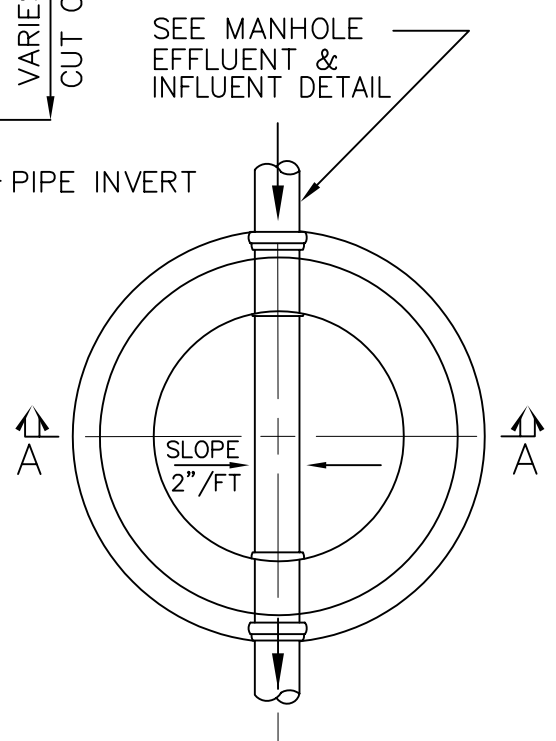

PLAN VIEW

TO BE USED WHEN CUT CLASSIFICATION IS 6'-0" OR LESS

NOTES

1. SEE MANHOLE NOTES ON DRAWING NO. S-4
2. SEE STANDARD MANHOLE CASTING DRAWING NO. S-3
3. SEE PIPE OPENING DETAIL DRAWING NO. S-10
4. SEE MANHOLE EFFLUENT & INFLUENT DETAIL DRAWING NO. S-11

INDIAN RIVER COUNTY
DEPARTMENT OF
UTILITIES SERVICES



MANHOLE
STANDARD SHALLOW

JULY 2009

DRAWING
NO.
S-5